



SRE-3000 Elan Stairway Elevator **Technical Specifications**

rev: 03-08-2012
ILS-01024

MODEL NUMBER: SRE-3000
U.S. F.D.A. CLASSIFICATION: Class II
CLASSIFICATION NUMBER: 890.5150
PRODUCT CODE: ILK
ETL-Intertek C-US Listed: File Number: 100463819CHI-001

PERFORMANCE STANDARDS:

PRIVATE RESIDENCE ONLY

ANSI/ASME: A18.1-2005 (Sec. 7) Safety Standards for Platform Lifts and Stairway Chairlifts

ANSI/ASME: A18.1-2008 (Sec. 7) Safety Standards for Platform Lifts and Stairway Chairlifts

ANSI/ASME: A18.1-2011 (Sec. 7) Safety Standards for Platform Lifts and Stairway Chairlifts

CSA B613 Private Residence Lifts for Persons with Physical Disabilities

ANSI/ASME: CSA B44.1/ASME-A17.5 Elevator and Escalator Electrical Equipment

RATED LOAD: 300 lb (136 kg) maximum

NUMBER OF PASSENGERS: 1

POWER SOURCE: 24VDC comprised of 2 each 3AH 12 volt sealed maintenance-free lead acid batteries;
On/Off power switch to prevent battery drain over lengthy storage periods

CHARGER: 120VAC/1.5 A input, 24VDC/1 A output continuous monitoring, full primary cut off

DRIVE: 24VDC, 16A direct drive self-locking positive geared motor, 2 pole rated 442 Lb-in (50Nm) torque,
25.5 rpm output speed, with right angle worm gear box

FINAL DRIVE: integrated 8dp gear rack on rail with a spur gear on the gearbox output shaft

MOTOR CONTROLLER: custom 24VDC PWM controller with acceleration ramping

BRAKING: dynamic motor braking through the motor controller, worm gear box, electro-mechanical motor
brake and overspeed protection

CALL/SEND CONTROL: infra-red wireless control; momentary switching requiring a user to
continuously hold button to control unit

ARMREST CONTROL: 3-position, momentary rocker switch requiring user to continuously hold rocker
switch to control unit; switch mounted under armrest

SUPPORTS: clamps anchored to stair tread; normal rail position is 2" (50.8 mm) above step nose;
number of clamps dependent on the length of rail; optional height-adjustable clamps
available

ANGLE: 22 to 45 degrees (specials up to 52 degrees)

SPEED: maximum top speed 15 ft/min (0.08 m/s); actual speed varies depending on rider weight

Bruno Independent Living Aids, Inc., 1780 Executive Drive, P.O. Box 84, Oconomowoc, WI 53066
Phone (800) 882-8183 Fax (262) 953-5501

Any reproduction or other use of these materials without written permission of Bruno Independent Living Aids, Inc. is expressly prohibited.
Bruno Independent Living Aids, Inc. reserves the right to modify or make changes to these specifications at any time without notice.

LENGTH OF TRACK: 15 feet 9 inches (4.9 m) and 19 feet 8 inches (6.1 m) standard; dealer to cut to fit the actual length of the stair (see application guide)

TRACK CONSTRUCTION: aluminum extruded rail with covered metal gear rack; bolted joint plate at each rail joint

FOOTREST: folding footrest with safety sensor panel

SEAT: padded, folding and swivel with stops at 0° (forward), 67° (top), and 90° (top); no swivel at lower landing; multiple-position seat height adjustments.

ARMRESTS: fixed to seat frame; armrest may be individually rotated towards seat back for smaller profile when not in use and to facilitate transfers

SAFETY EQUIPMENT:

- 1) seat swivel switch allowing operation only when chair is in center position
- 2) carriage safety switches
- 3) seat positioning belt
- 4) carriage safety switches
- 5) 25A manual reset breaker on motor control circuit
- 6) final end stop bumper at each end of rail
- 7) final limit switch
- 8) full diagnostic alarms on circuit board
- 9) armrest safety switches to insure barrier arms down to operate
- 10) Overspeed protection against free fall or run away condition
- 11) charging light on charger
- 12) 5A fuse on control circuits

BATTERY CAPACITY/POWER OUTAGE:

Cycles: variable depending on angle, length of run, ambient temperature, and rider weight
Batteries: between 12 and 24 hours if power is disconnected

WEIGHT OF UNIT:

185 lb (86 kg) without rider in a typical 15'-9" (4.9 m) installation

TESTING PERFORMED:

- 1) Life cycle testing with full rated load at 45 degree on a 15'-9" rail
- 2) battery charger UL tested and listed to UL 1310
- 3) self locking gear box statically tested with 2100lb (953kg)(7 times rated load) on a 45-degree rail for 5 minutes with no carriage movement; test performed at manufacturer's location
- 4) repetitive tests performed to determine power outage cycling
- 5) electrical discharge to ground testing performed for FDA 510(k)
- 6) Overspeed free fall testing for repeated usage

OPTIONS:

- 1) manual folding rail

**Bruno Independent Living Aids, Inc., 1780 Executive Drive, P.O. Box 84, Oconomowoc, WI 53066
Phone (800) 882-8183 Fax (262) 953-5501**

Any reproduction or other use of these materials without written permission of Bruno Independent Living Aids, Inc. is expressly prohibited.
Bruno Independent Living Aids, Inc. reserves the right to modify or make changes to these specifications at any time without notice.

TECHNICAL DATA/SPECIFICATION

MODEL: SRE-3000 ELAN STRAIGHT RAIL STAIRLIFT, PRIVATE RESIDENCE ONLY

RATED LOAD: 300 LBS, ONE PASSENGER

POWER SOURCE: 24 VOLT DC COMPRISED OF (2) 3 AMP/HR
12 VOLT SEALED BATTERIES
120 VOLT AC 1.5 AMP, 24 VOLT DC 1 AMP
CONTINUOUS MONITORING CHARGER.

DRIVE: 24 VOLT DC DIRECT DRIVE SELF LOCKING POSITIVE GEARED MOTOR,
2 POLE RATED RIGHT ANGLE WORM GEARBOX,
50Nm (442in.lb.) TORQUE, 25.5 RPM SPEED, 16 AMP CURRENT.

SUSPENSION: RACK & PINION - INTEGRATED 8DP GEAR RACK
ON RAIL WITH SPUR GEAR ON THE OUTPUT SHAFT
OF GEARBOX.

BRAKING: DYNAMIC MOTOR BRAKING THROUGH THE MOTOR
CONTROLLER, WORM GEAR, ELECTRO-MECHANICAL
MOTOR BRAKE AND OVERSPEED PROTECTION.

CONTROLS: CONTINUOUS PRESSURE ROCKER SWITCH LOCATED
ON THE ARMREST AND WALL MOUNTED CALL/SEND
CONTROLS LOCATED AT BOTH THE TOP AND BOTTOM
LANDINGS.

ANGLES: 22 TO 45 DEGREES (SPECIALS UP TO 52 DEGREES),
RIGHT OR LEFT HAND ORIENTATIONS.

FINAL LIMIT SWITCH: STANDARD

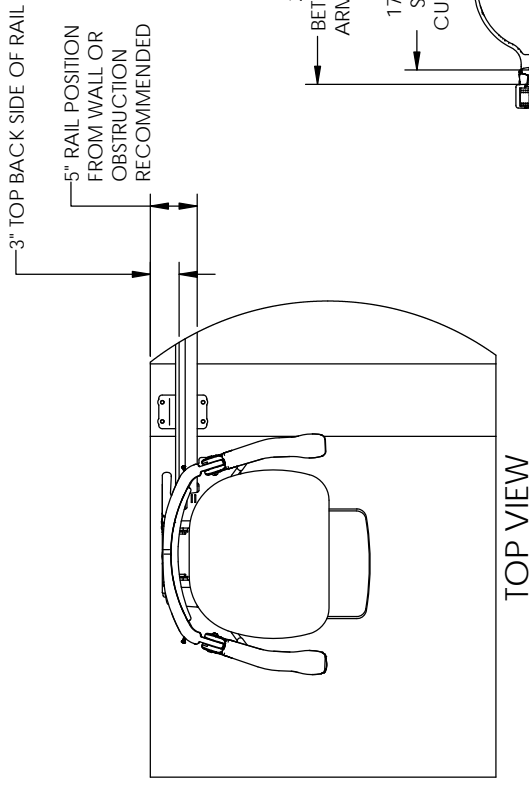

TOP VIEW

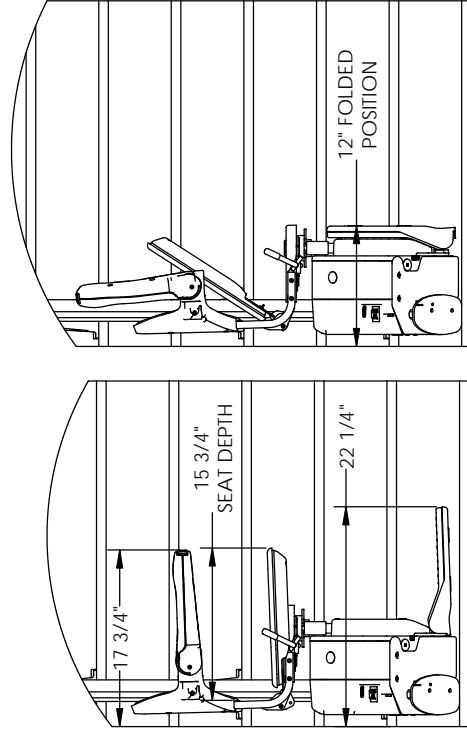

SIDE VIEWS

DIMENSIONS SHOWN IN SIDE VIEWS
ARE BASED ON 4-1/2" RAIL POSITION
FROM WALL OR OBSTRUCTION

LOWER LANDING EXTENSION DIMENSIONS ARE
BASED ON 45 DEGREE RAIL SLOPE ON AN
8" 1ST RISER HEIGHT. DIMENSIONS WILL VARY
BASED ON SLOPE AND RISER HEIGHT.

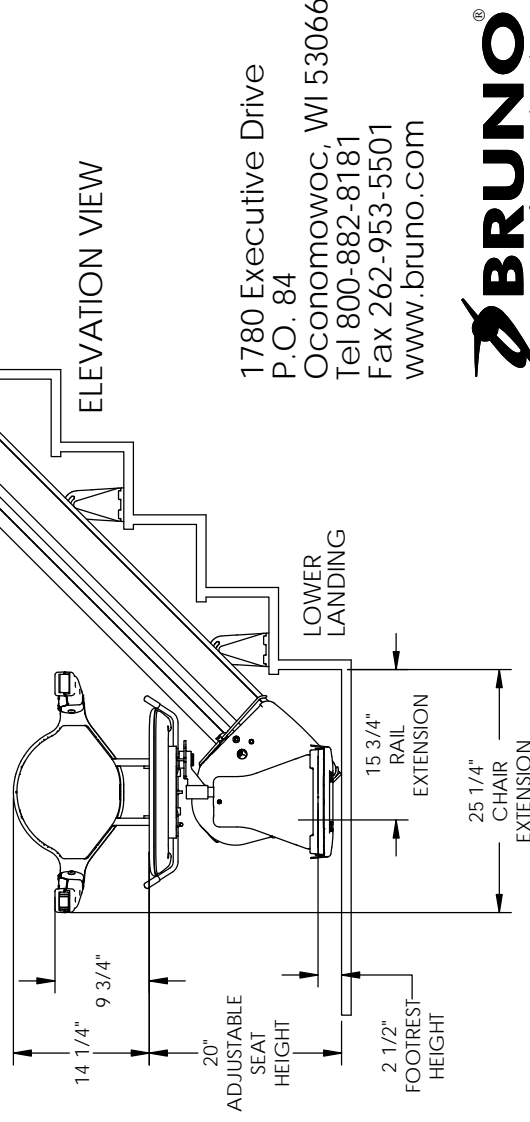

ELEVATION VIEW

1780 Executive Drive
P.O. 84
Oconomowoc, WI 53066
Tel 800-882-8181
Fax 262-953-5501
www.bruno.com



© Bruno Independent Living Aids, Inc

ILS-01021
SHEET 1 OF 2
REV. 3-9-12

SRE-3000 FOLDING RAIL

AUXILIARY ELEVATION VIEW
RAIL FOLDED DOWN POSITION

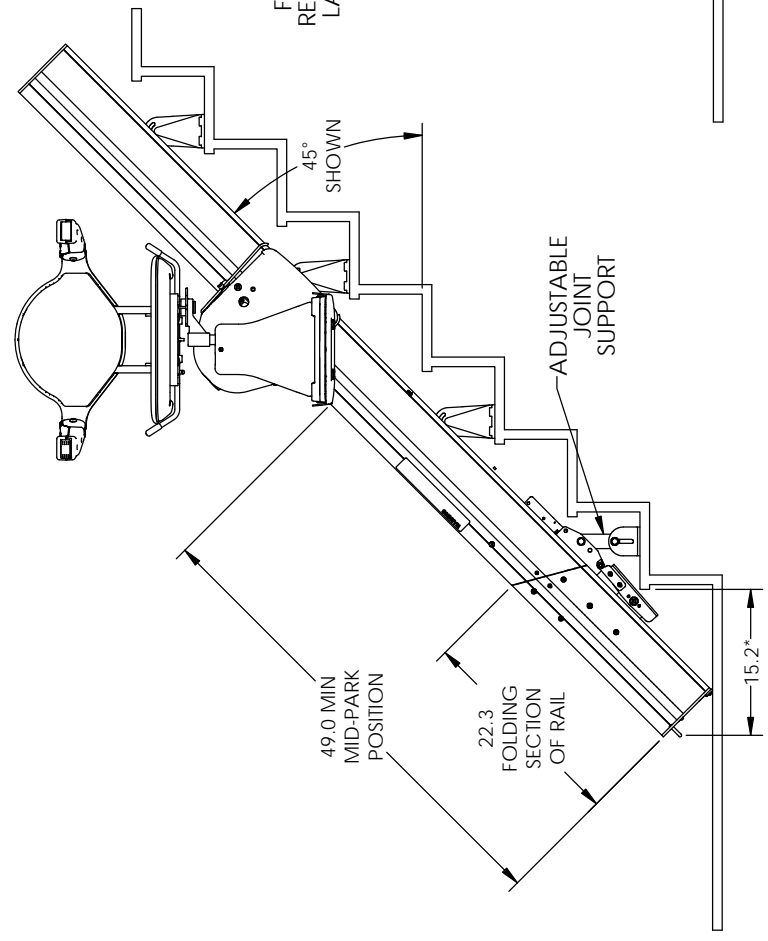

AUXILIARY ELEVATION VIEW
RAIL FOLDED UP POSITION

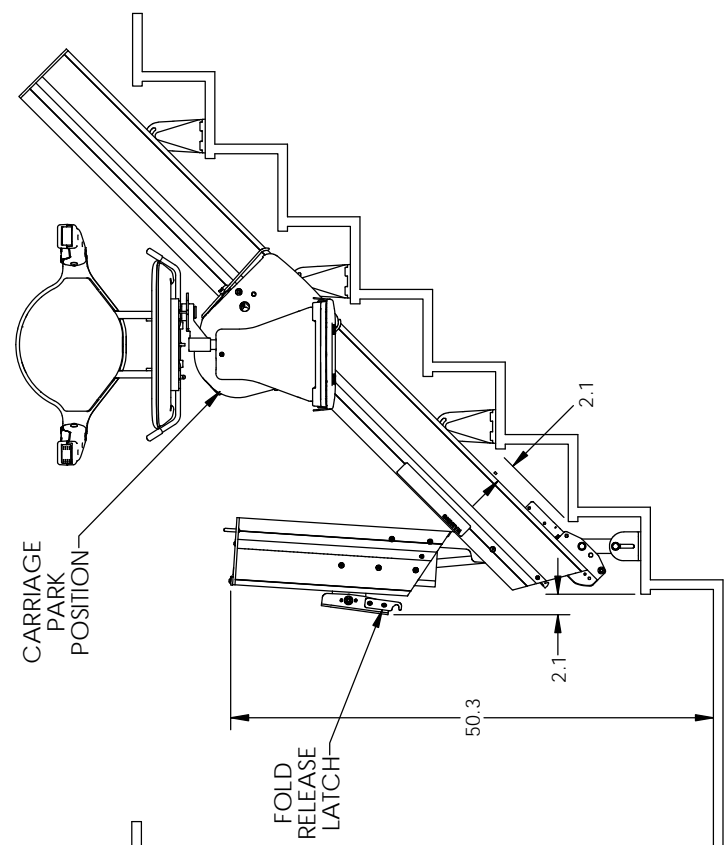

*LOWER LANDING EXTENSION DIMENSIONS ARE BASED ON 45° RAIL SLOPE AND 8" RISER HEIGHT. DIMENSIONS WILL VARY BASED ON SLOPE AND RISER HEIGHT.